

Passenger Van Cargo Barrier Instructions

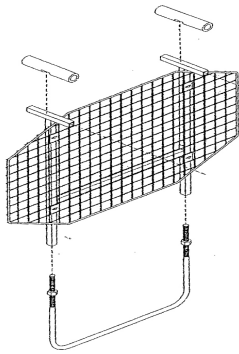

Assembly Instructions

1. thread the 2 large nuts on to the threaded ends of the base hoop. Slide the threaded ends of the base support hoop into the uprights attached to the screen.
2. Tighten the 4 bolts on the screen.
3. Place the top support with the foam pads in the top of the uprights.

Final Assembly Location

1. Place the barrier behind the first or second row of seats as shown.
2. Tighten the 2 nuts, with the wrench provided, until the barrier will no longer move.
3. Tighten the set screws on each of the nuts with the included Allen key.

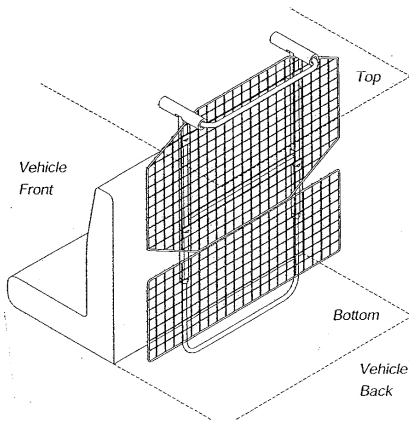

Optional Lower Screen

1. After placing the barrier into the vehicle, using the Velcro Zip-Ties provided attach the lower screen.
2. Attach 2 Zip-Ties to the bottom of the upper screen.
3. Place the remaining Zip-Ties around the lower screen and bottom support loop.

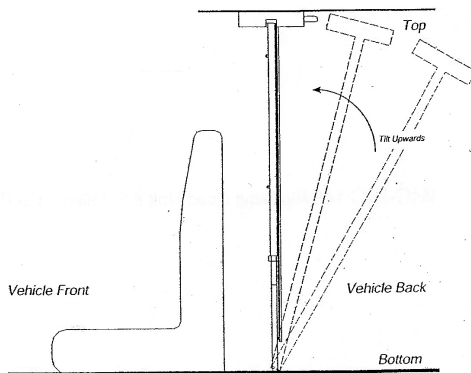

Note: Do not worry about over tightening nuts, it will not damage the unit

Maintenance Procedure

It is recommended that if the barrier is not removed on a regular basis that you periodically check to ensure it is supported with the proper amount of pressure. Please follow the steps below.

1. Securely grip the barrier and give it a firm shake. If the barrier has any movement see step 2.
2. Using the wrench provided with your barrier, tighten the 2 base nuts until the barrier no longer has any movement. Then tighten the Set Screws on each nut with the Allen key provided.